

XXIII. *On Uniform Rotation.* By C. W. SIEMENS, F.R.S., Mem. Inst. C.E.

Received March 10,—Read April 12, 1866.

AMONGST the means at our disposal for obtaining uniform rotation, there is none for which the same degree of accuracy can be claimed as that which distinguishes the vibrating pendulum, or the oscillating spring-wheel of the common watch; yet there are many purposes, both in physical science and in the mechanical arts, for which smaller subdivisions of time than the period of one oscillation are matter of considerable importance, and which can only be measured by uniform rotation.

Conical Pendulum.—The apparatus by which continuous rotation of the greatest regularity has hitherto been obtained, is the conical pendulum, which was first applied by JAMES WATT to regulate the speed of his engines, and which has since received further development in the instrument known as the Chronometric Governor.

On examining into the principle involved in the conical pendulum, it will be found that the time t of its rotation is dependent upon its length l , and on the angle α which it makes with its vertical axis of rotation, which dependence is expressed by the formula

$$t = \phi \sqrt{l \cos \alpha},$$

the coefficient ϕ being a function due to gravitation. The value of t being dependent upon α , it follows that “*uniform rotation of a conical pendulum cannot be obtained except on condition that the angle of its rotation remains constant.*”

WATT'S Governor.—In the case of WATT'S centrifugal governor, the angle of rotation of the pendulum varies with every change in the relative condition of power and load on the engine, and the change of angle is, indeed, taken advantage of to close or open the steam-supply valve. In order to close the steam- (or throttle-) valve the angle of rotation has to be increased, which necessitates a corresponding increase of the engine's velocity; on the other hand, an increase of the valve-orifice cannot be effected without a reduction of the speed of the engine taking place.

Considering this dependence of the action of the instrument upon permanent change of speed of the engine, the name of “governor” seems inappropriate, the instrument being, in fact, only a “moderator” of the amount of fluctuation to which the engine would be subjected without its agency. The amount of these fluctuations depends, in a great measure, upon the mechanical construction of the instrument, which is, generally speaking, very objectionable, inasmuch as the pendulous arms are mostly suspended at points beside the common axis of rotation, giving rise to an increased variation of time for a given change of angle; the reason being that the true pendulous length has to be measured from the point of intersection of the pendulums or rods with the axis of

rotation, which point descends as the angle increases, causing the pendulous length to diminish at both extremities. A better result would be obtained if each pendulous rod were suspended from the point past the axis of rotation (as shown by dotted lines in fig. 1), causing the two rods to cross in the line of the axis at a point which would rise with increase of angle, and render the true pendulous length approximately uniform between certain limits.

The governor of WATT is, however, subject to another defect which does not admit of an easy rectification, and which consists in its want of power to operate on the steam-valve at the moment when the equilibrium between the power and load on the engine is disturbed. It will be seen that while the engine proceeds uniformly, gravitation and centrifugal force must be in equilibrium as regards the governor-balls, but at the moment when, for instance, a portion of the load on the engine is removed, steam-power will be set at liberty for accelerating the fly-wheel. This acceleration proceeds in accordance with the well-known gravitation laws until the increase of centrifugal force imparted to the governor-balls suffices to overcome the friction of the valve and its mechanical connexions, which are not inconsiderable. In the mean time the speed of the engine will have been increased to an extent considerably beyond what is required in order to maintain the valve in its new adjustment; the action of the governor, when it does take place, will therefore be excessive, and a series of fluctuations in the speed of the engine must follow before the proper readjustment of its valve can be effected.

Chronometric Governor.—Impressed with these imperfections in WATT'S centrifugal governor, I proposed, twenty-three years ago, in connexion with my brother, WERNER SIEMENS, a governor based also on the conical pendulum, which in this case was to be independent in its action of change in its angular rotation, and, moreover, was to be provided always with a store of power ready to overcome the resistance of the valve at the first moment when the balance between the power and load of the engine was disturbed. This instrument (the chronometric governor) has been applied with success in many cases where engines were required to work with great regularity under varying conditions of load; it has also received an interesting application by the Astronomer Royal for regulating astronomical and chronographical instruments, proving the high degree of precision of which it is capable.

The leading idea involved in this governor consisted in providing a conical pendulum in *uniform rotation*, and in establishing a *differential motion* between it and the wheel driven by the engine, which differential motion was made to act upon the source of power of the latter. If this idea could be carried out, it was evident that the engine, or machine to be governed, must suit its motion closely to that of the independent rotating pendulum, because the least retardation on its part must immediately result in an enlargement of the valve-orifice (it being understood that an increase of available power

Fig. 1.

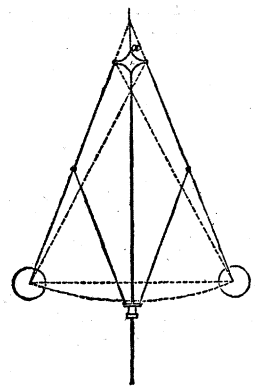

is always obtainable), and the least motion in advance of the pendulum must automatically reduce the source of power. This action would be effected instantly, notwithstanding a considerable resistance in the valve, because the weight of the pendulum in rotation represents, in this case, a store of power, inasmuch as its angular velocity would have to be suddenly checked or increased as the case may be, unless the valve obeyed the first appearance of a differential motion. In order to realize these conditions, it was necessary to maintain the conical pendulum in question at a uniform angle of rotation, notwithstanding the changes of driving- or sustaining-power which must necessarily arise through its action upon the regulating valve of the engine; and this could only be accomplished by providing the means of destroying or absorbing any excess of driving-power beyond what was necessary to overcome the friction of the instrument, and which must tend otherwise to increase its angle of rotation. On the other hand, a surplus of driving-power had to be provided to prevent an occasional collapse of the pendulum in opening the valve. The sustaining- or driving-power of the pendulum was obtained in taking advantage of the differential motion, a weight being attached to a horizontal lever upon the throttle-valve spindle, which, in exerting a pressure of the differential wheel against the two principal wheels, caused an impulse to be given to the one connected with the pendulum, whereas the third wheel was driven by the engine in the direction proper to raise the weight continually. The excess of driving-power imparted to the pendulum was destroyed by calling into action a friction between two solid substances at the moment when the angle of rotation had reached its intended maximum; or a liquid resistance was introduced, such as a fan, rotating with the pendulum, being dipped into a bath of mercury or other liquid, at the moment when the extension of the pendulum was attained (see fig. 2).

The governors constructed on this principle are remarkable for their instantaneous action upon the supply-valve of the engine, when a sudden disturbance of the balance between load and power takes place; and they possess also, to the fullest extent, the power of maintaining the regulated machine at the same speed, when the load reaches its maximum, as when it is at its minimum. In the hands of the Astronomer Royal the uniformity of motion obtained by the use of this governor approaches indeed that of an ordinary chronometer, yet it is not free from objections resulting from the delicate adjustment and frequent attention requisite to maintain it in good working condition. In its application to the regulating of physical

Fig. 2.

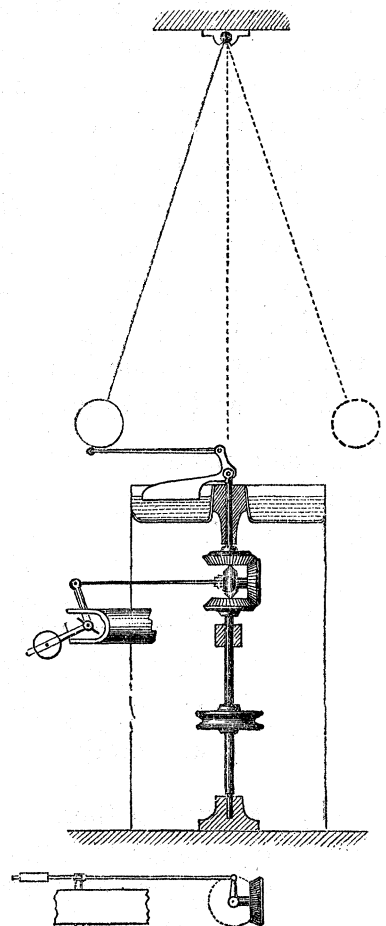

apparatus it has, moreover, been found that the conical pendulum is apt to fall into elliptical rotation, whereby the subdivisions of time below the half second become inaccurate.

FOUCAULT'S Governor.—Monsieur FOUCAULT, of Paris, has treated the same question in a different manner, substituting for the friction between solids, or of solids against fluids which we employed to fix the angle of rotation of the conical pendulum, the varying resistance of an air-propeller, according to the amount of area for the escape of air, which area he regulates by means of the angular elevation of his conical pendulum. The conical pendulum he employs is mounted in the manner of a WATT'S governor of the best construction, which renders his apparatus portable, and therefore convenient for general purposes, while, on the other hand, it appears to depend for its correct action upon the perfect condition of many mechanical details.

Some months since an idea suggested itself to me which, while it furnishes the elements of a very general and complete solution of the problem under consideration, appears to possess also a separate scientific interest, which chiefly induces me to bring the subject before the Royal Society.

Liquid in rotation.—If an open cylindrical glass vessel or tumbler containing some liquid be made to rotate upon its vertical axis, the liquid will be observed to rise from the centre towards the sides to a height depending on the angular velocity and the diameter of the vessel. As soon as the velocity has reached a certain limit, the liquid will commence to overflow the upper edge of the vessel, being thrown from it in the form of a fluid sheet in a tangential direction. If the velocity remain constant from this moment, the overflow of the liquid will be observed to cease, although the liquid remaining in the vessel will continue to touch the extreme edge or brim. Supposing that the velocity of the vessel be now diminished, the liquid will be observed to sink, but will rise again immediately to its former position when the rotation returns to its previous limit of angular velocity. This velocity is the result of the balance of two forces acting on the liquid particles, namely, gravity and centrifugal force.

It is a well-known fact that the curvilinear surface produced by a liquid in rotation is that of a paraboloid, the parameter of which is expressed by $\frac{g}{w^2}$, and the curve itself therefore by the formula

$$y^2 = \frac{2g}{w^2} x, \dots \dots \dots (I.)$$

- x* signifying vertical distance from the apex,
- y* the corresponding horizontal distance from the axis of rotation,
- w* the angular velocity of rotation, and
- g* acceleration by gravity in one second.

In this formula there is no factor denoting the density of the liquid, which proves that the point to which the liquid is raised by a given angular velocity is independent of the specific gravity of the liquid employed.

By substituting for *y* the radius *r* of the rotating cup at the brim, and for *x* the height

h of the brim above the lowest level of the liquid, we may write the foregoing general formulæ as follows,

$$h = \frac{r^2 w^2}{2g}, \dots \dots \dots \text{(II.)}$$

and

$$w = \frac{\sqrt{2gh}}{r}; \dots \dots \dots \text{(III.)}$$

two convenient formulæ for determining the height to which liquid will rise when the diameter of the rotating vessel and its angular velocity are given, or for determining the angular velocity due to a given height and diameter, it being understood that the values of g , r and h must be expressed in the same unit of length.

If it is desired to determine the number of revolutions per second n , instead of the angular velocity w , we may put

$$n = \frac{w}{2\pi},$$

and in putting this value for w ($=2\pi n$) into the last formula, we have

$$n = \frac{\sqrt{2gh}}{2r\pi} \dots \dots \dots \text{(IV.)}$$

These formulæ are applicable to vessels of every possible external form rotating upon their vertical axis, and to every possible liquid, but they are based upon the supposition that the liquid is raised by rotation to the upper edge or brim of the vessel, a condition which it may appear at first sight difficult to realize for practical purposes.

If the production of uniform rotation be the object in view, it is necessary that the liquid in the rotating vessel should always be at the point of overflow, although the driving-power might vary considerably, and that all surplus driving-power should be absorbed by other work than that of accelerating the rotating vessel, also that the stock of liquid within the vessel should never diminish. I hope to prove by the following demonstration that these various conditions can be fulfilled by suitable mechanical arrangements resulting in the construction of a simple and efficient instrument, which is represented on Plate XXIX., and which has survived the ordeal of experimental proof.

Liquid Gyrometer.—The rotating vessel consists, in this case, of a cup C (Plate XXIX. fig. 1) open both at the top and bottom, but widest at the top, the sides being made to close in towards the bottom in a parabolic curve analogous to that formed by the liquid in rotation. This cup contains upon its inner surface three or four radial ribs which unite in a central boss, by which the cup is supported upon the spindle S. This support is not an absolute one, but the spindle is armed with a screw-thread of rapidly ascending path, into which the screw-threads upon the inner surface of the boss are made to fit; a fixed connexion between the driving-spindle and the cup C is established by means of a spiral spring E, one end of which is fastened to the projecting end of the spindle S, and the other to the cup. Before this spring is fixed, it is drawn out longi-

tudinally to such an extent as to balance the weight of the cup, which latter may therefore be said to float upon the screw-threads without exercising any pressure upon the same. The upper support of the spindle S is a boss projecting from the bottom of a cylindrical vessel B of glass sides and glass-domed top, which completely encloses the cup C, while it renders its action visible: this outer vessel is filled with liquid to such a height as to submerge the lower edge of the cup. Rotation of the liquid in the outer vessel is prevented by radial ribs upon its bottom surface; and upon the external surface of the rotating cup C two concentric projections are provided, one at the upper edge, and the second near the surface of the outer liquid, for the purpose of throwing off some liquid which would otherwise be apt to adhere to the external surface of the cup, in defiance of centrifugal force, and interfere slightly with its proper action.

Rotation being imparted to the shaft S and the cup C by clockwork or from any other source, the liquid at the bottom of the cup will be acted upon by centrifugal force and rise upon its inner sides, while additional liquid will enter from without and maintain the apex of the liquid curve nearly on a level with the surrounding lake. At the moment when the liquid in rotation touches the upper edge of the cup, the speed should be such as is determined by the formula

$$n = \frac{\sqrt{2gh}}{2r\pi},$$

in which h may be taken for the height of the brim of the cup above the lake surface; but considering that the power necessary to maintain the cup at its velocity, after the liquid has been raised to its upper edge, is exceedingly small, because no fresh material has to be put into motion, it would be practically impossible to prevent further acceleration. In order to make sure that the liquid will not fall below the brim of the rotating cup, an excess of driving-power must be applied, and that excess must be disposed of otherwise than in producing further acceleration of the cup. This is accomplished by means of a continual overflow of a thin sheet of liquid, which is projected against the sides of the outer vessel and falls back into the lake at the bottom, whence a similar quantity of liquid penetrates into the cup, to be also raised by its rotation and projected over its edge.

The power absorbed in raising and projecting the liquid must be strictly proportionate to the quantity of liquid so acted on in a given time, or to the thickness of overflow, provided the condition of uniform velocity be realized; but the velocity of the cup depends upon the height to which the liquid has to be raised, and must therefore be increased in order to raise the liquid column above the brim of the cup. The necessary increase of velocity to produce such an overflow is not great, considering that the height of the liquid column increases in the square ratio of the velocity, and may be neglected in all cases where only approximate results are required, or where variations in the driving-power are comparatively small; but no high degree of accuracy could have been claimed for this instrument unless the following compensating action had suggested itself:—

Automatic Dip of Cup.—We have assumed hitherto a rigid connexion between the cup and its driving-spindle, and unless the cup does overflow, we are, indeed, justified in this assumption, the spring E being too rigid to yield to the resistance of the cup in motion when no work is performed. With an increase of power the resistance of the cup also increases, and an overflow of liquid proportionate to the power is produced; the connecting spring E must yield, at the same time, proportionately to the torsional resistance thus created, and in the same ratio the cup will descend upon the helical surface which serves for its guide. While, therefore, on the one hand, the h of our formula increases with the overflow, it is diminished, in the same ratio, by the descent of the cup, both depending directly upon the driving-power. When the stiffness and length of the spring are so adjusted that the one action equals the other for any given increase of power, it must equal it also for other amounts of increase within reasonable limits, and *strictly-uniform rotation must be the result*. The “reasonable limits” to this automatic adjustment are imposed by the restricted orifice through which the liquid has to penetrate into the cup, and also by the range of action of the spring, for which the law of MARIOTTE is applicable. Experiments, to be hereafter described, have shown that the driving-power may be varied between wide limits without producing any sensible variation of speed. The final adjustment of the instrument to the normal velocity required is moreover easily effected by raising or lowering the cup while it is running, for which purpose the lower end of the upright spindle S is supported in the axis of an adjusting screw E, as will be seen by inspection of Plate XXIX. fig. 1.

Range of power increased.—The range of power through which uniform rotation can be obtained, may be further increased by an arrangement which is represented in Plate XXIX. figs. 2 and 6, and which consists in arresting the liquid projected over the edge of the cup by a belt of fixed vanes M, whence it drops through the zone of rotating radial vanes L, which again impart tangential motion to it at the expense of the superfluous driving-power of the cup of which they form part. It is hardly necessary to add that these fixed and rotating vanes only *increase the range of power of the instrument, without in any way affecting its rate of rotation*, and that a second set of fixed and rotating vanes might be added with the same effect as the first. Although the rotating cup represented in Plate XXIX. figs. 2 and 6, is not provided with the automatic dip, it is equally evident that the fixed and moveable vanes do not preclude that arrangement, which is only dispensed with in such cases where great uniformity of motion is not required.

An interesting application of such a “Liquid Gyrometer,” as this instrument may appropriately be called, would be that of obtaining synchronous motion at different places connected by a telegraphic wire, for philosophical or telegraphic purposes; but in order to test its fitness for such purposes, I have constructed a clock of which it constitutes the regulating principle, the moving power being obtained by electro-magnetism.

Clock regulated by liquid in rotation.—This clock is represented by Plate XXX. figs. 7 & 8, and consists of three principal parts:—

1. The pedestal containing a battery of two "MARIE DAVY'S elements" suitably arranged.

2. The body of the clock, with sides formed of plate glass, containing an electromagnet, by which rotatory motion is imparted to an iron bar or keeper fixed upon the vertical main axis which passes into

3, the regulating chamber, consisting of a close cylindrical glass vessel with domed glass top containing the rotating cup and a certain quantity of paraffin oil, which fluid is particularly applicable on account of its perfect fluidity and non-affinity for the materials composing the regulator.

The regulating cup is in this instance formed of vulcanite, and is suspended from the top of the vertical axis by means of a spiral spring, which, being fixed at both ends, not only supports the weight of the cup but acts also as a torsional spring, enabling the cup to descend upon its helical central guide whenever an increase of driving-power calls into existence its equivalent of torsional resistance.

The rings of stationary and rotating vanes are dispensed with in this instance, because no great variations in the driving-power are contemplated. The electromagnet acts by attraction of the armature during a small portion of its rotation, and one contact only is required, which is so arranged that no destruction of the metallic surfaces can arise through the discharge of extra-current sparks, which latter are received by an elastic point of platinum slightly in advance of the proper contact surface and moved by the same excentric. By this simple arrangement the usual difficulty attending dry contacts is avoided, and a continued action of the instrument ensured. A train of reducing wheels communicates the motion of the cup-spindle to hands upon the face of the clock, which record hours and minutes in the usual manner.

The diameter of the rotating cup being = 0.040 metre, and the height of its edge over the surface of the liquid = 0.034 metre, the number n of its rotations per second in accordance with our formula

$$n = \frac{\sqrt{19.6 \text{ metre} \times .038 \text{ metre}}}{.040 \text{ metre} \pi} = 6.9 \text{ revolutions per second.}$$

Experiment gave, on the contrary, a speed of 7.5 revolutions per second, or .6 revolution per second more than was indicated by theory, a result which seemed to stamp the action of the instrument with uncertainty, when it was recollected that no allowance had been made for the aperture at the bottom of the cup, leaving a portion of the rotating liquid without an external support.

Correction for lower orifice of Cup.—If we assume, for instance, that the sides of the cup were cylindrical and merely descended below the surface of the liquid without closing in at the bottom, we should find that by rotation of this cylinder, supposing the inner surface to be rough or armed with radial projections, the liquid would rise on the circumference above the external level of surface, but would also form a depression or vortex in the centre of rotation. The surface of the rotating liquid would be that pro-

duced by the rotation of a vertical parabola, as represented in the accompanying diagram.

In order to maintain the hydrostatic equilibrium between the rotating column and the external liquid, it is necessary that its mean height of column should remain the same, or that the plane of external liquid level should divide the solid figure comprised between the cylinder and the curve of rotation into equal parts. In order to realize these conditions experimentally, it would be necessary to provide the lower portion of the rotating cylinder with an easy fitting and balanced piston, without which circular currents would be produced within the rotating liquid (descending by force of gravity at the sides, and rising again in the centre) and mar the result.

The body comprised between a paraboloid of the height h' and a cylinder is, however, divided equally by a horizontal plane cutting it at the distance of $\frac{h'}{\sqrt{2}}$ from the edge, or at

$$h' - \frac{h'}{\sqrt{2}} = .293h'$$

from the apex. The form of the curve depends upon the angular velocity alone, and would remain the same if the upper diameter of the tube were to be increased, only the curve would in that case have to be continued until it met the sides (as shown by dotted lines), and to the extent of these prolongations the liquid would be raised higher above the external level without producing a corresponding depression in the centre of rotation.

It follows that the aperture at the bottom of the rotating cup causes a vortex or depression of the apex of the curve of rotation below the external liquid to the extent of .293 part of the height due to its own diameter, and to the correct number of rotations n' per second.

Now

$$n' = \frac{\sqrt{2g(h + .293h')}}{2r\pi},$$

and also

$$n' = \frac{\sqrt{2gh'}}{2g\pi}$$

if ρ is the radius of lower aperture of cup; therefore

$$\frac{\sqrt{2g(h + .293h')}}{2r\pi} = \frac{\sqrt{2gh'}}{2g\pi},$$

or

$$h' = h \frac{\rho^2}{r^2 - .293\rho^2};$$

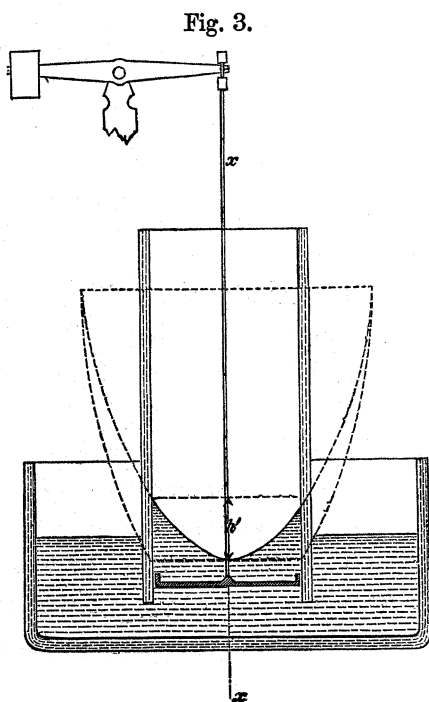

and in substituting this value for h' in the first formula, we have

$$n' = \frac{\sqrt{2gh + 2gh \frac{g^2}{r^2 - 293g^2}}}{2r\pi},$$

or

$$n' = \frac{\sqrt{2gh \left(1 + \frac{g^2}{r^2 - 293g^2}\right)}}{2r\pi}, \dots \dots \dots (V.)$$

for our *corrected formula to determine the velocity of cup with continuous overflow.*

In applying this formula to the clock, taking for g its value of 8 millims. and the other values also in millimetres in order to avoid fractions, we find

$$n' = \frac{19600 \times 38 \left(1 + \frac{64}{400 - 16 \cdot 05}\right)}{40\pi} = 7 \cdot 4 \text{ revolutions per second,}$$

or $\cdot 1$ revolution per second less than the actual speed. This remaining excess of the *actual* over the *calculated* velocity of the cup is rather more than what may be fairly attributed to error of measurements, and appears to be due to adhesion of a film of liquid (which may be estimated at nearly $\cdot 25$ millimetre thickness) to the inner sides and edge of the cup, whereby its *effectual* dimensions are proportionately reduced. For a uniform speed this error must be a constant quantity, which cannot affect the working of the instrument injuriously, so long as the other conditions are such as to produce uniform rotation. The discrepancy is diminished by increasing the dimensions of the cup, and its amount is such that the compensation is effected, under all circumstances, by one or two turns of the regulating screw supporting the vertical spindle.

When the regulation of the cup is once effected, it continues to rotate at a remarkably uniform rate. Change of temperature affects the density of the liquid considerably, but does not influence the rate of the cup otherwise than inasmuch as it affects the level in the cup-chamber, rising with increase of temperature proportionately to the depth of liquid it contains, which change is inconsiderable. The lineal dimensions of the cup, and the length of the suspending spring, will also increase, all tending to lower the rate with increase of temperature; but, on the other hand, the length of the upright cup-spindle increases with increase of temperature, and by regulating the length and composition of that spindle properly, entire compensation for change of temperature is effected. The cup-chamber being entirely closed against the atmosphere, no fault can arise through evaporation or dispersion of the liquid within moderate periods of time.

In the case of the clock under consideration, no compensation for change of temperature was provided, nor is the cup entirely balanced by the spring, yet its rate is as uniform as that of the common clock with which it has been compared; but in order to test the regulating-power of the instrument, the driving-power was varied by the introduction of artificial resistances into the galvanic circuit, when the following results were observed:—

Time of common clock, in seconds.	Mercury units of resistance of clock and battery.	Units of resistance put into circuit.	Relative value of driving-power.	Time of liquid gyro-meter clock, in seconds.	Variations in time produced, in seconds.
720	110	0	100	736	16 slow
720	110	10	92	734	14 „
720	110	20	85	734	14 „
720	110	30	78	733	13 „
720	110	40	73	732	12 „
720	110	50	69	731	11 „
720	110	60	64	729	9 „
720	110	70	61	726	6 „
720	110	80	58	723	3 „
720	110	90	55	720	correct
720	110	100	52	723	3 fast
720	110	110	50	726	6 „
720	110	120	48	725	5 „
720	110	130	46	724	4 „
720	110	140	44	722	2 „
720	110	150	42	729	9 slow

when the overflow had ceased

This result shows that the spring employed was decidedly too weak, producing a *decrease of speed with increase of power*.

A more careful adjustment of the spring would improve these results, which suffice, however, to prove the capabilities of the instrument.

It appears at first sight as though the friction of the cup upon the threads of the screw must interfere with its automatic adjustment; but this is practically not the case, owing to the circumstance that small fluctuations in the resistance continually occur, causing torsional oscillations of the cup, the mean of which must be its true position notwithstanding friction, which friction moreover is reduced to a minimum, owing to the suspension of the weight by the spring.

Another interesting quality of the gyrometric cup is its comparative indifference to a vertical position; it may, indeed, be tipped very considerably without interfering with the uniform overflow all round, and the time of its rotations is diminished only in the ratio of the square roots of the vertical mean heights, or it is

$$n' : n = \sqrt{h} : \sqrt{h \cos \beta},$$

or for a tipping angle $\beta = 3^\circ$,

$$n' : n = 1 : 1.0007,$$

showing that no particular care is requisite to place the instrument upon a horizontal foundation.

Gyrometric Governor.—The most useful practical application of this instrument is that of regulating the power and velocity of steam-engines. A cup of very large dimensions, provided with several belts of check-vanes and with the automatic dip arrangement, might be conceived which, being connected by gearing with the main shaft of an engine, would limit its velocity by absorbing directly all its surplus power. This surplus power would appear in the cup-chamber in the form of molecular motion or heat,

and would have to be got rid of by the application of cooling agents, if the natural dispersion of heat by radiation would no longer suffice to keep down the temperature. This would, however, be a wasteful proceeding, and it becomes necessary to operate, not upon the power produced, but rather upon the source of power, by rendering it always equal to the accidental resistance or load in order to maintain uniform velocity. The arrangement adapted for this purpose is represented by Plate XXIX. figs. 2, 3, 4, 5 & 6.

S is the main shaft of the engine, which imparts motion to the upright spindle H carrying an inverted wheel E. The axis A of the regulating cup, being concentric with the spindle H, carries a pinion F, and both the wheel and the pinion gear into two intermediate or planet-wheels G and G', which latter are loose upon studs and are suspended from a rocking-frame I, the latter being free to turn upon its central support. The rocking-frame I is connected by a rod R to a bell-crank lever O, which is fastened upon the spindle of the steam-regulating or throttle-valve V; but the horizontal arm of the lever O carries a weight P which, being acted upon by gravity, tends to open the valve and at the same time to force the rocking-frame I, with its planet-wheels G and G', round the vertical axis. This pressure is resisted, on the one hand, by the teeth of the pinion F, which can only yield in the ratio imposed by the rotating cup C, and on the other hand, by the teeth of the inverted wheel E, which latter, being driven round by the engine in the direction contrary to the effort produced by the weight P, causes the latter to be continually raised. If the engine should succeed in raising the weight P, say 100 millims., while the regulating cup yields also to the extent of 100 millims., then the lever O, and with it the regulating valve V, will retain their relative position; but if the engine should raise it, say 95 or 105 millims., while the cup yields 100 millims., then the valve will be either opened or closed by 5 millims., and the engine will be urged or checked, as the case may be, to such an extent as to make its revolutions coincide again absolutely with those of the regulating cup.

The driving-power of the cup is limited by the weight P, and may be considered as a constant regulated quantity (although it is derived indirectly from the engine); but whenever the valve has to be opened or closed, a resistance arises which goes either in diminution of or in addition to the weight P, and the power of the cup must be such that its speed remains sufficiently uniform under the influence of these occasional variations.

By means of the automatic dip arrangement it would not be difficult to obtain perfect uniformity, notwithstanding these irregularities in the driving-power; but in the case of steam-engine governors this arrangement is dispensed with for the sake of a more immediate action upon the valve at the moment when a differential velocity arises. Supposing that the greatest amount of occasional variation of speed is to be 1 per cent., and that the dimensions of the cup are as follows,

Diameter at upper rim	=200 millims.
Diameter of rim above the liquid	=200 millims.
Diameter of orifice at bottom of cup	= 90 millims.

we find the available power of the instrument in the following manner:—

The normal speed of a cup of these dimensions is, according to our formula,

$$n = \frac{\sqrt{19600 \times 200 \left(1 + \frac{45^2}{100^2 - 293 \times 45^2}\right)}}{200\pi} = 3.31 \text{ revolutions per second.}$$

The height to which the liquid is raised by rotation increases in the square ratio of the speed of rotation, the increase of height due to 1 per cent. increase of speed would therefore result from the following proportion,

$$100 v : 101 v = \sqrt{h} : \sqrt{h'},$$

or the height due to the increased speed,

$$h' = 204 \text{ millims.,}$$

that is to say, the liquid would be raised 4 millims. above the brim of the cup, which, being an unbalanced column, will produce an upward flow of the liquid in the cup, as expressed by the well-known formula,

$$v = \sqrt{2gh};$$

or h being in this case = 4 millims., we have

$$v = .280 \text{ metre flow per second,}$$

which, if multiplied by the least sectional area at the entrance into the cup = .0057 square metre, gives the quantity of liquid

$$.280 \text{ metre} \times .0057 \text{ square metre} = .0016 \text{ cubic metre,}$$

or 1.6 litre of liquid raised 204 millims. high and projected with a velocity of

$$\frac{1.6}{100} 3.31 \times 2r\pi = 2.1 \text{ metres per second}$$

over the brim of the cup, to be stopped by the stationary wings and once more accelerated by the rotating wings, which, being one-fifth more in diameter than the cup itself, impart to the liquid a velocity of

$$\frac{6}{5} 2.1 = 2.5 \text{ metres per second.}$$

These accelerations represent a power which, according to the formula

$$h = \frac{v^2}{2g},$$

is equal to the same liquid being lifted

for $v = 2.1$ metres . . . to .225 metre height,

and for $v = 2.5$. . . to .320 metre height.

In the cup it was lifted to .200 metre height,

making a total lift . . . to .745 metre height.

If the liquid employed is water, the 1.6 litre represents 1.6 kilogram., and the resistance produced by 1 per cent. increase of velocity is

$$1.6 \times .745 = 1.2 \text{ kilogrammetres per second,}$$

which is equivalent to *forcing a valve rod or lever through one decimetre space in ten seconds against a resistance of 120 kilograms.*

This force exceeds by far what is usually required of a governor, and fits the new instrument for the accomplishment of objects which hitherto could not be attempted, such for instance as regulating the power of engines by the link motion or other variable expansion gear (whereby a considerable saving of fuel may be effected), or moving the gate of a water-wheel.

The most striking feature of this governor is, however, the rapidity with which a readjustment between power and load of an engine is effected; experiment has proved that *two-thirds of the total load upon an engine may be suddenly thrown off without producing any visible change in its rotation.* It must be borne in mind that the variation of 1 per cent., which was assumed in calculating the power of the instrument, applies only to the short period of ten seconds, during which the readjustment of the valve is effected, after which the cup and, with it, the engine returns to its normal rate of rotation; but an increase or decrease of speed of 1 per cent. during ten seconds is so small a total amount that it is not perceptible to the eye, and may be regarded as non-existing for practical purposes.

A uniform velocity of engines, such as is secured by this instrument, is of considerable practical importance in spinning, grinding corn, and other manufacturing operations, because it not only prevents breakages and irregularities in the quality of the work produced, but it enables manufacturers to attain to the maximum speed at which their work can be produced.

It has been shown that the rotating cup is not sensitive to tipping, a circumstance rendering the gyrometric governor also applicable to marine engines, which are much in need of a means for maintaining a uniform speed, particularly where the screw propeller is used, which, in being raised by waves above the water, allows the engine to fly off at a dangerous speed.

The gyrometric cup appears therefore to be equally applicable for maintaining powerful machinery at a nearly uniform velocity, and for obtaining the higher uniformity of rotation requisite for philosophical and telegraphic instruments.

GYROMETRIC GOVERNOR. FOR STEAM ENGINES

Fig. 2.

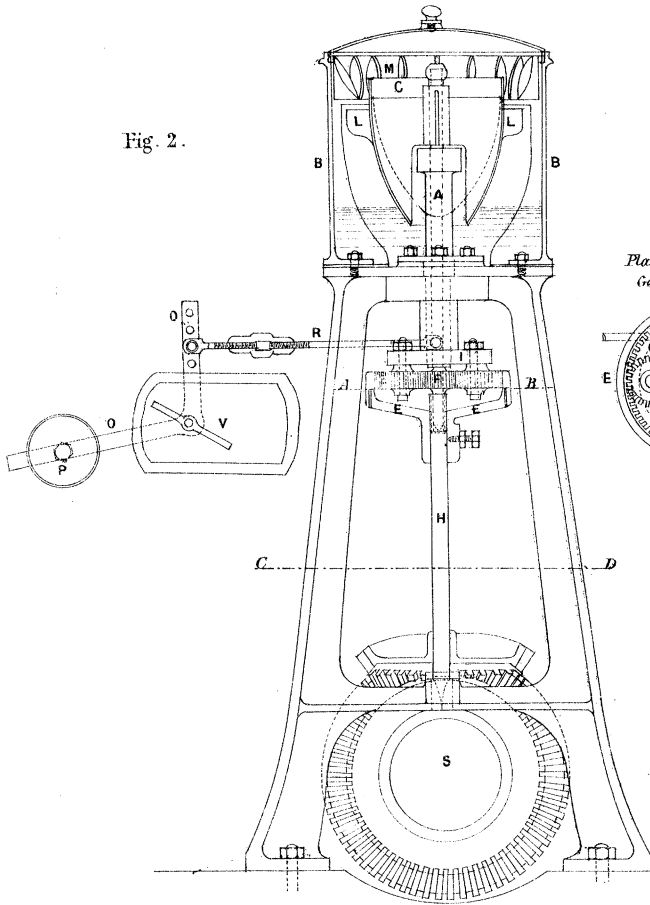
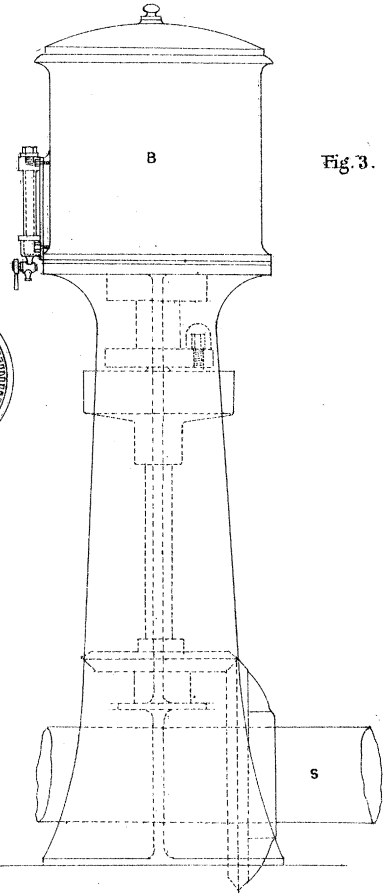

Fig. 3.



Plan of differential
Gearing at A.B.

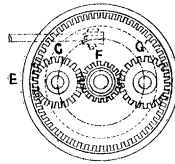

Fig. 4.

Sectional Plan at C.D.

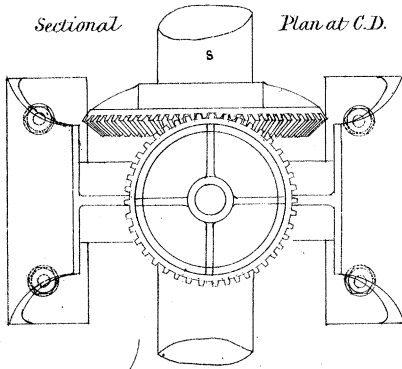

Fig. 5.

Plan with cover off
showing tap.

Fig. 6.

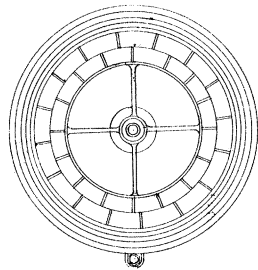
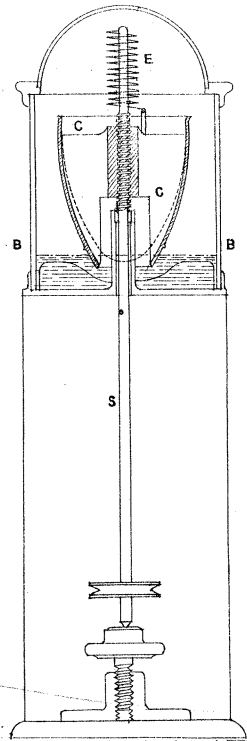
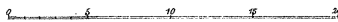

Fig. 1.



SCALE OF INCHES.



SECTIONAL ELEVATION.

ELECTRIC CLOCK.

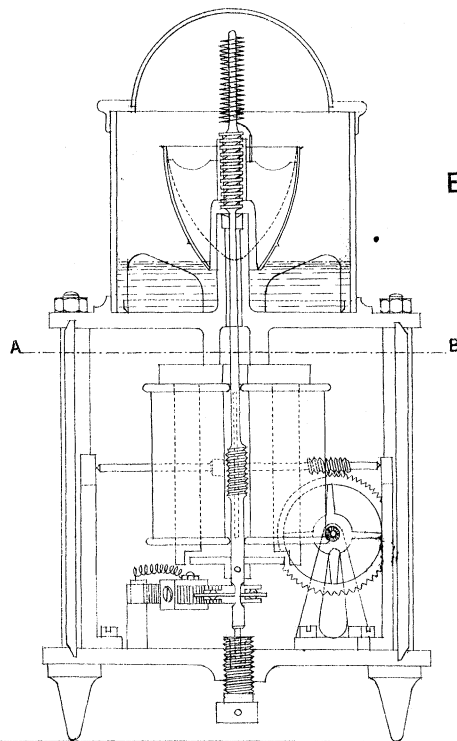
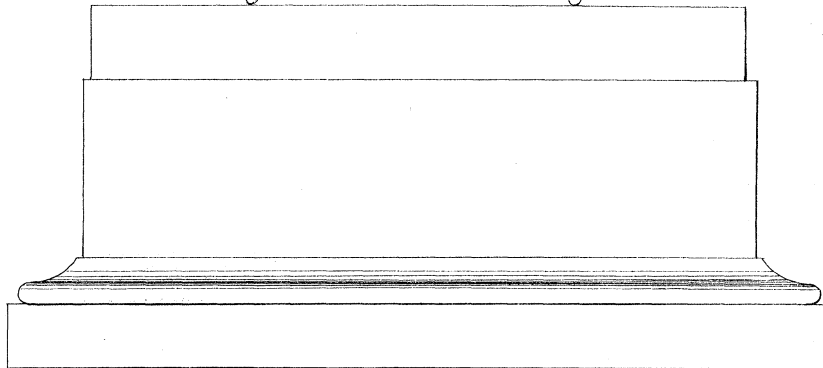

Fig. 7.



SECTIONAL PLAN AT A.B.

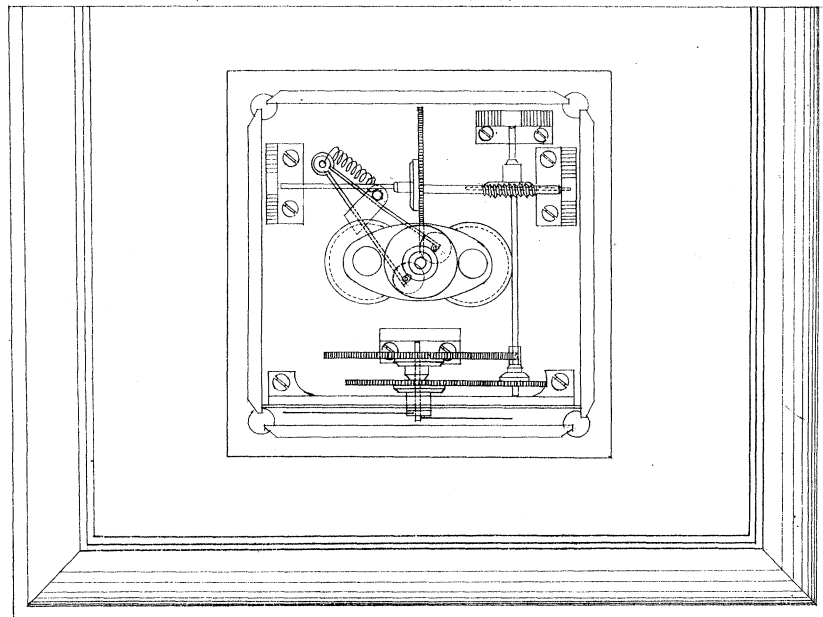

Fig. 8.

SCALE OF INCHES

